

# R58

FILTERED AND RECTANGULAR CONNECTORS

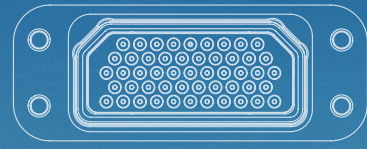

# R58

Amphenol Canada is the only qualified supplier for the Mil Spec JN1122



**Amphenol** CANADA  
MILITARY & AEROSPACE

# Amphenol CANADA

MILITARY & AEROSPACE

For more than 50 years, Amphenol Canada Corp. a subsidiary of Amphenol Corporation has been an international leader in the manufacture of Rectangular I/O and EMI Filtered Connectors.

We design, manufacture and test EMI / EMP filter and non-filter connectors, which are used worldwide in military, aerospace, and commercial applications. As part of Amphenol Corporation, we have the advantage of access to technologies and processes of Amphenol's worldwide facilities. Our expertise in understanding and supporting our customers' interconnect needs has earned us a reputation of excellence among the world's leading users of electronic components.

## CUSTOMER SERVICE

At Amphenol Canada, customer service is a solid commitment from all our employees. Our product managers, application engineers, product specialists, and sales representatives are able to answer your questions and assist you in choosing the right connectors for your applications.

Using Amphenol's on-line computer system, we are able to promptly update you on your order status, provide you with price and delivery quotations, and address any problems or questions you might have.

Whether you need standard or custom designed connectors, our marketing department is your liaison with Amphenol Canada's engineering, quality and manufacturing experts.

## QUALITY AND RELIABILITY

Certified to ISO 9001:2015 + AS9100:2016 (certification available at [www.amphenolcanada.com](http://www.amphenolcanada.com)), Amphenol Canada's broad base of customers and the high levels of technology in which they are involved make it essential that Amphenol's own products are of the highest quality and reliability.

Please contact us for RoHS requirements.

# R58



## TABLE OF CONTENTS

Introduction   Specification . . . . .	4
How to Order . . . . .	5-6
Insert Arrangements Size A . . . . .	7
Insert Arrangements Size B . . . . .	8
R58 Size A & B Plugs . . . . .	9
R58 Size A & B Receptacle . . . . .	10
Mounting Styles . . . . .	11-14
How to Order Backshells . . . . .	15
<b>Filter:</b>	
Filter Overview . . . . .	16
Filter Parameters . . . . .	17
Filter Construction, Technical Details . . . . .	18
Filter Plots . . . . .	19
Filter How-to-order . . . . .	20

# Introduction and Specifications

R58

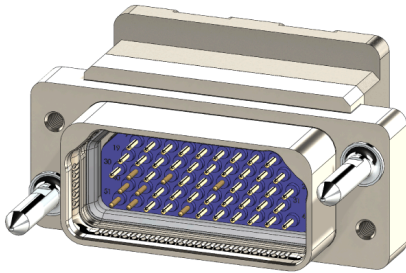
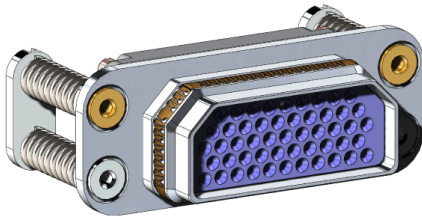
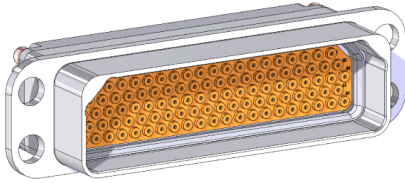

Filter Connector

The Amphenol R58 series are high-performance environment-resistant, rectangular connectors designed to be compatible with all MIL-DTL-83733 connectors and Amphenol Canada is interchangeable with all M83733 connectors and the only qualified supplier for the Mil Spec JN1122.

## FEATURES & BENEFITS

- Harsh environmental applications
- Shield and corrosion resistance
- Rear release crimp snap-in contacts
- Field proven assembly allow contacts to be inserted and extracted from the rear
- Contacts are qualified to Military Specifications

The connectors are available in two shell sizes with a variety of hard and spring mounting configurations.

A broad range of contact arrangements is available from custom to 185 standard contacts. The standard contacts are available in sizes 12, 16, 20 and 22D in crimp and PCB. Fiber optic contacts are also available. Shells are machined aluminum alloy with several finish options, including Olive Drab Chromate over Cadmium, and Electroless Nickel.

Insulators are a high grade, thermoplastic. Silicone rubber is used for grommets, inter-facial seals and peripheral seals.

Filtered versions are also available (458 Series).

## SPECIFICATIONS

### DIELECTRIC WITHSTAND VOLTAGE:

- 1300 VAC for size 22 contacts
- 1500 VAC for power contacts
- 500 VAC for shield contacts

### INSULATION RESISTANCE:

- 5000 MΩ @ 500 VDC
- Temperature range of -55°C to +125°C

### CONTACTS:

- Contacts are M39029/57 & M39029/58 for size 22D, and M39029/4 & M39029/5 for sizes 20, 16 & 12.
- Size 12 coax is M39029/50 & M39029/51. Fiber-Optic contacts available

### CONTACT TERMINATIONS:

- Crimp, PCB

MATERIALS:	
Shell	Aluminum Alloy
Insert	Thermoplastic
Hardware	CRES=Corrosion Resistant Stainless Steel
Contact Retention	BeCu=Beryllium Copper

### PART NUMBER KEY

1. Military	2. Connector Series	3. Base / Number	4. Class	5. Shell Size	6. Insert Pattern A or B
<b>M</b>	<b>83733</b>	<b>/7</b>	<b>R</b>	<b>B</b>	<b>051</b>

### STEPS PART # DESCRIPTION

<b>1. MILITARY</b>	<b>M</b>	Military- Amphenol Canada offers a commercial equivalent to the M83733 Military specification
--------------------	----------	---

<b>2. CONNECTOR SERIES</b>	<b>83733</b>	
----------------------------	--------------	--

<b>3. BASE SLASH NUMBER</b>	<b>/ NO.</b>	<b>CONTACT GENDER</b>	<b>MOUNTING STYLE</b>	
	<b>/1</b>	Receptacle (Pin)	G	(4x) .281 (7.14) Thru Holes
	<b>/2</b>	Plug (Socket)	X	(2x) Guide Pins, (2x) Spring Mounts
	<b>/3</b>	Receptacle (Pin)	X	(2x) Guide Sockets, (2x) 6-32 mounting holes
	<b>/4</b>	Plug (Socket)	K	(4x) .138-32 UNC-2B Mounting w/ Captive Spring Mount Assembly
	<b>/5</b>	Receptacle (Pin)	C	(4x) .138-32 UNC-2B Self-Locking Bushings
	<b>/6</b>	Receptacle (Pin)	F	(4x) .138-32 UNC-2B Clinch Nuts
	<b>/7</b>	Plug (Socket)	Y	(2x) .138-32 UNC-2B Mounting, w/ Spring Mount Assembly, (2x) Guide Sockets
	<b>/8</b>	Receptacle (Pin)	Y	(2x) Guide Pins, (2x) 6-32 mounting holes
	<b>/9</b>	Receptacle (Pin)	M	(2x) .281 (7.14) Thru Holes
	<b>/10</b>	Receptacle (Pin)	H	(2x) .138-32 UNC-2B Self-Locking Bushings
	<b>/11</b>	Receptacle (Pin)	Z	(2x) .138-32 UNC-2B Clinch Nuts
	<b>/12</b>	Plug (Socket)	H	(2x) .138-32 UNC-2B Mounting, w/ Spring Mount Assembly

<b>4. CLASS</b>	<b>R</b>	Environmentally Resistant
	<b>S</b>	Space Environment Applications

<b>5. SHELL SIZE</b>	<b>A</b>	Small Shell
	<b>B</b>	Large Shell

<b>6. INSERT PATTERN A</b>	<b>018</b>	18x sz 12 Contacts
	<b>032</b>	32x sz 16 Contacts
	<b>051</b>	51x sz 20 Contacts
	<b>131</b>	131x sz 22D Contacts

<b>6. INSERT PATTERN B</b>	<b>030</b>	30x sz 12 Contacts
	<b>048</b>	30x sz 16 Contacts - 18x sz 12 Contacts
	<b>59W7</b>	52x sz 16 Contacts - (W7) 7x COAX Contacts
	<b>064</b>	64x sz 16 Contacts
	<b>071</b>	56x sz 20 Contacts - 15 x sz 12 Contacts
	<b>71C15</b>	56x sz 20 Contacts - (C15)15x sz 12 Contacts
	<b>078</b>	38x sz 20 Contacts - 40x 16 Contacts
	<b>101</b>	101x sz 20 Contacts
<b>185</b>	185x sz 22D Contacts	

# Commercial How-to-Order

R58

## PART NUMBER KEY

1. RoHS Compliance	2. Connector Series	3. Shell Size	4. Insert Patterns A or B	5. Contact Gender	6. Termination Style	7. Mounting Style	8. Shell Finish
<b>E</b>	<b>R58-</b>	<b>B</b>	<b>018</b>	<b>P-</b>	<b>T</b>	<b>X</b>	<b>N</b>

STEPS	PART #	DESCRIPTION
<b>1. ROHS COMPLIANCE</b>	<b>E</b>	RoHS Compliant (Omit for non-RoHS compliant connectors)
<b>2. CONNECTOR SERIES</b>	<b>R58-</b>	Rectangular M83733 Style
<b>3. SHELL SIZE</b>	<b>A</b>	Small Shell
	<b>B</b>	Large Shell
<b>4. INSERT PATTERN A</b>	<b>018</b>	18x sz 12 Contacts
	<b>032</b>	32x sz 16 Contacts
	<b>051</b>	51x sz 20 Contacts
	<b>084</b>	86x sz 22 Contacts - 2x COAX Contacts
	<b>105F4</b>	101x sz 22 Contacts - 4x sz 16 Fiber Contacts
	<b>131</b>	131x sz 22D Contacts
<b>4. INSERT PATTERN B</b>	<b>030</b>	30x sz 12 Contacts
	<b>048</b>	30x sz 16 Contacts - 18x sz 12 Contacts
	<b>59W7</b>	52x sz 16 Contacts - (W7) 7x COAX Contacts
	<b>064</b>	64x sz 16 Contacts
	<b>071</b>	56x sz 20 Contacts - 15 x sz 12 Contacts
	<b>71C15</b>	56x sz 20 Contacts - (C15)15x sz 12 Contacts
	<b>078</b>	38x sz 20 Contacts - 40x 16 Contacts
	<b>101</b>	101x sz 20 Contacts
<b>5. CONTACT GENDER</b>	<b>P-</b>	Pin (Receptacle)
	<b>S-</b>	Socket (Plug) with EMI spring
<b>6. TERMINATION STYLES</b>	<b>B</b>	PC Tail
	<b>S</b>	Solder Cup
	<b>T</b>	Crimp
<b>7. MOUNTING STYLE</b>	<b>C</b>	S/B 4x.138-32 UNC-2B self locking bushings for receptacle
	<b>F</b>	(4x) .138-32 UNC-2B Clinch Nuts
	<b>G</b>	(4x) .281 (7.14) Thru Holes (Mounting hardware is separate)
	<b>H</b>	PIN (Recpt) 2x.138-32 UNC-2B Self Locking Bushings, Staggered Mount SKT (Plug) 2x.138-32 UNC-2B Spring Mounts, Staggered Mount
	<b>K</b>	4x.138UNC-2B Mounting w/Captive Spring Mount Assemblies
	<b>M</b>	(2x) .281 (7.14) Thru Holes (Mounting hardware is separate)
	<b>X</b>	PIN (Rcpt) 2x Guide Sockets, 2x.138-32 Mounting Holes SKT (Plug) 2x Guide Pins, 2x.138-32 Spring Mounts
	<b>Y</b>	PIN (2x) Panel Mount Hardware, (2x) Guide Pins SKT (2x) .138-32 UNC-2B Mounting, w/ Spring Mount Assembly, (2x) Guide Sockets
	<b>Z</b>	PIN (Rcpt) 2x Guide Pins, 2x.138-32 Mounting Holes SKT (Plug) 2x Guide Sockets, 2x.138-32 Spring Mounts
<b>8. SHELL FINISH</b>	<b>C</b>	OD Cadmium=Olive Drab Cadmium
	<b>N</b>	Electroless Nickel
	<b>Z</b>	Zinc Nickel

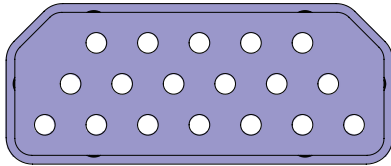

018	
QTY	Size
18	12

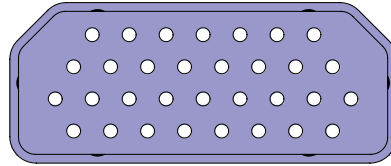

032	
QTY	Size
32	16

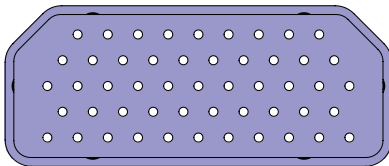

051	
QTY	Size
51	20

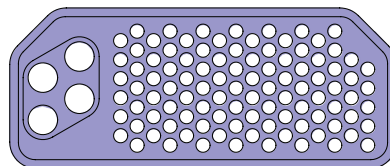

105F4	
QTY	Size
101	22
4	16 Fiber

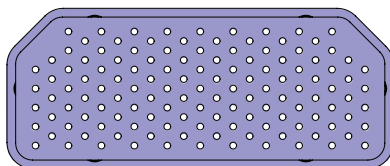

131	
QTY	Size
131	22 D

# Insert Patterns Size B

R58

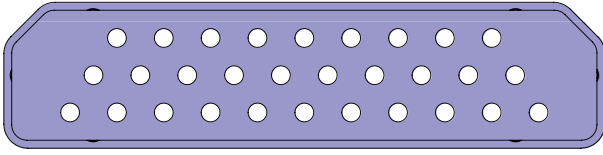

030	
QTY	Size
30	12

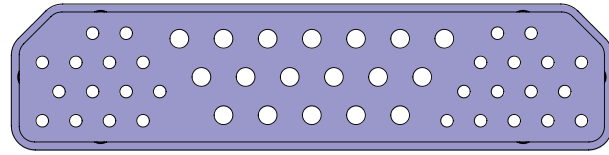

048	
QTY	Size
30	16
18	12

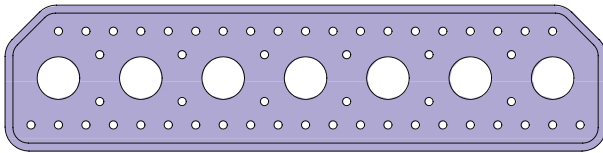

58W7	
QTY	Size
52	16
(W7) 7	Coax

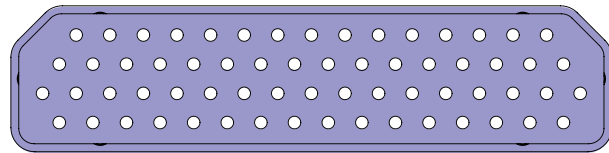

064	
QTY	Size
64	16

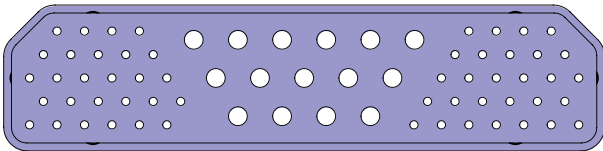

071 and 71C15	
QTY	Size
56	20
15	12 (12 COAX for 71C15)

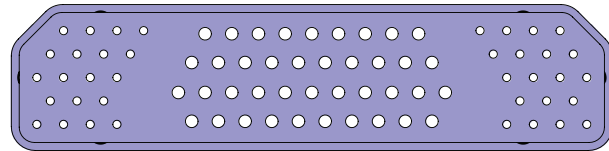

078	
QTY	Size
38	20
40	16

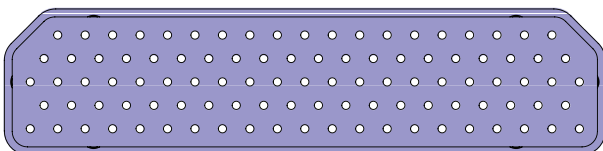

101	
QTY	Size
101	20

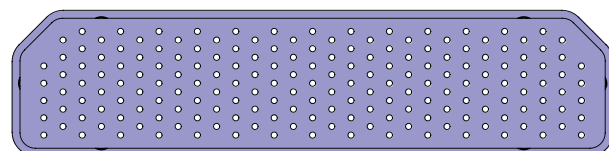

185	
QTY	Size
185	22D



## SIZE A PLUG

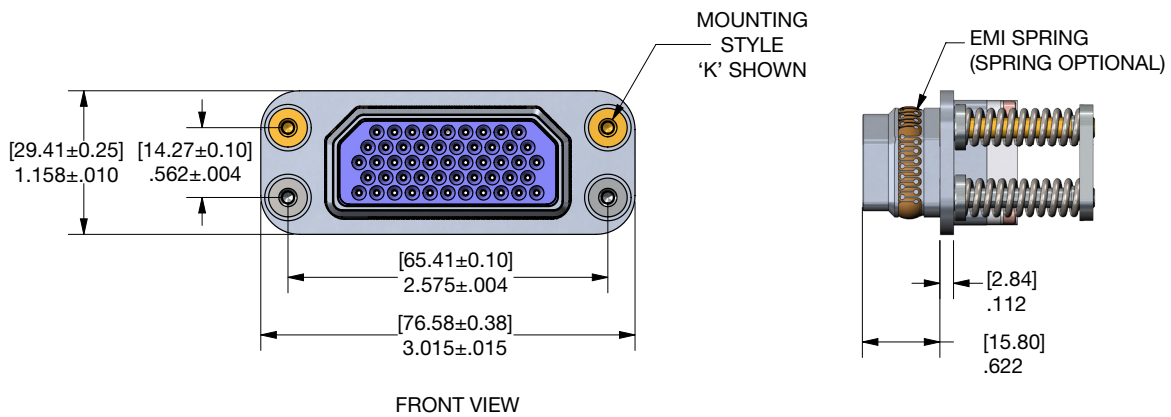
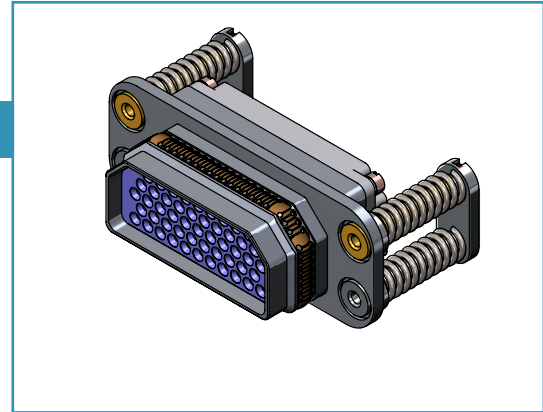

## SIZE B PLUG

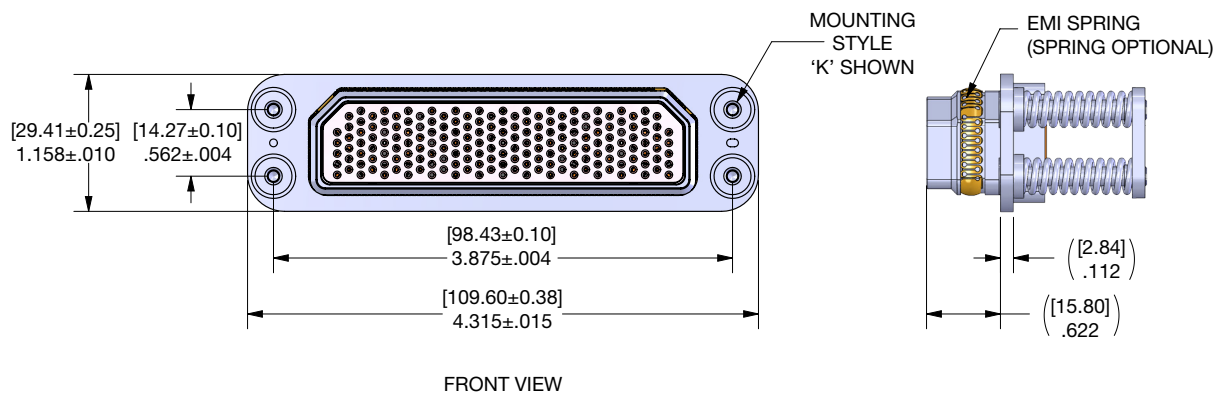
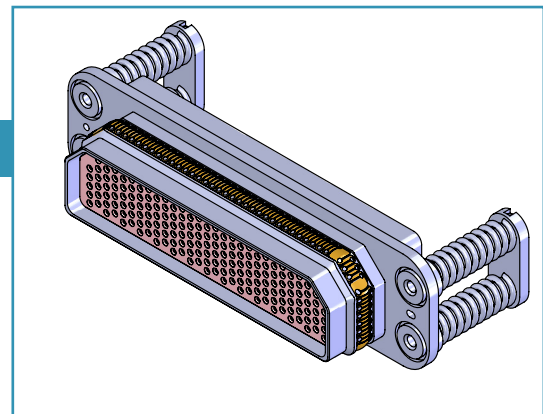

# Receptacles

R58

## SIZE A RECEPTACLE

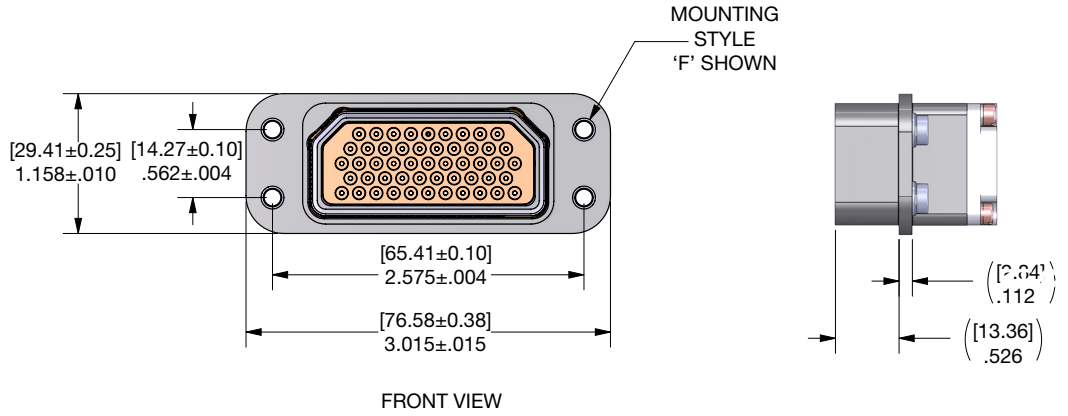
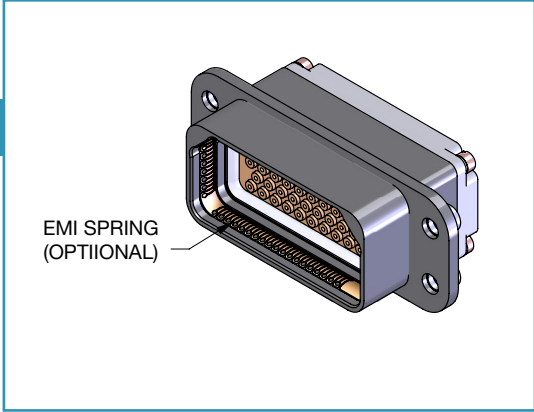

## SIZE B RECEPTACLE

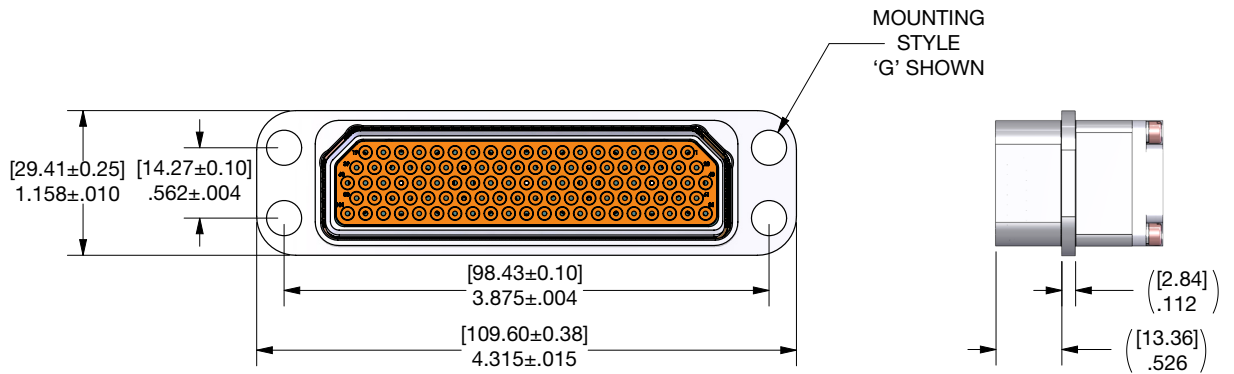
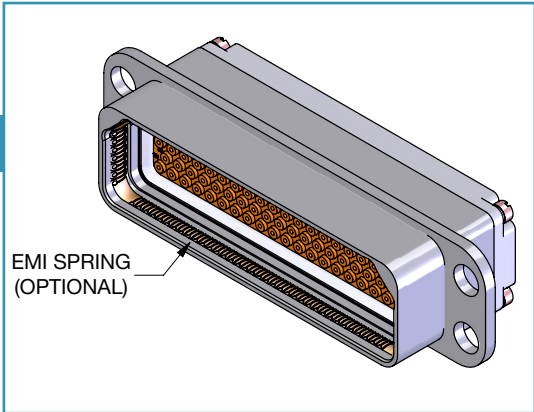

## TYPE C PIN MILITARY, SOCKET COMMERCIAL TYPE

M83733/5  
TYPE 'C' PIN  
MILITARY

TYPE "C" SKT  
WITH BUSHINGS  
COMMERCIAL  
VERSION

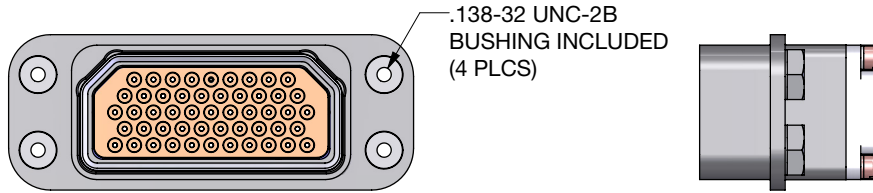

## TYPE F PIN MILITARY, SOCKET COMMERCIAL TYPE

M83733/6  
TYPE 'F' PIN  
MILITARY

TYPE 'F' SKT WITH  
CLINCH NUTS  
COMMERCIAL

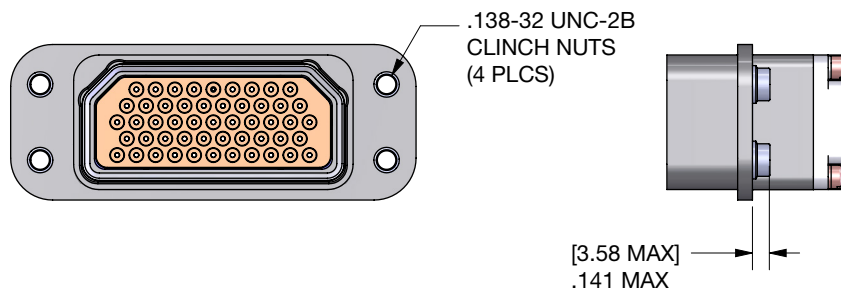

## TYPE G PIN MILITARY, SOCKET COMMERCIAL TYPE

M83733/1  
TYPE 'G' PIN  
MILITARY

TYPE 'G' SKT  
COMMERCIAL

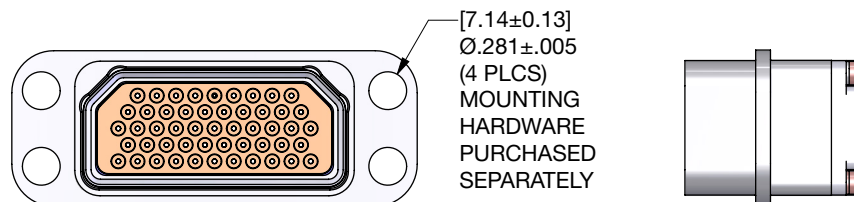

# Mounting Styles H Pin & Socket, K Socket

R58

## TYPE H PIN

M83733/10  
TYPE 'H' PIN

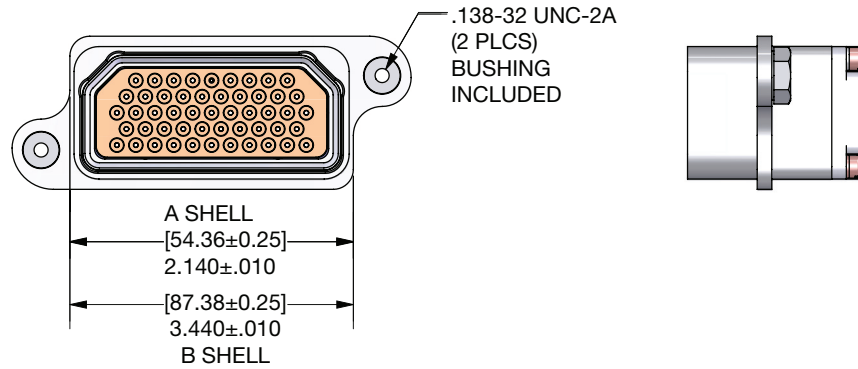

## TYPE H SOCKET

M83733/12  
TYPE 'H' SOCKET

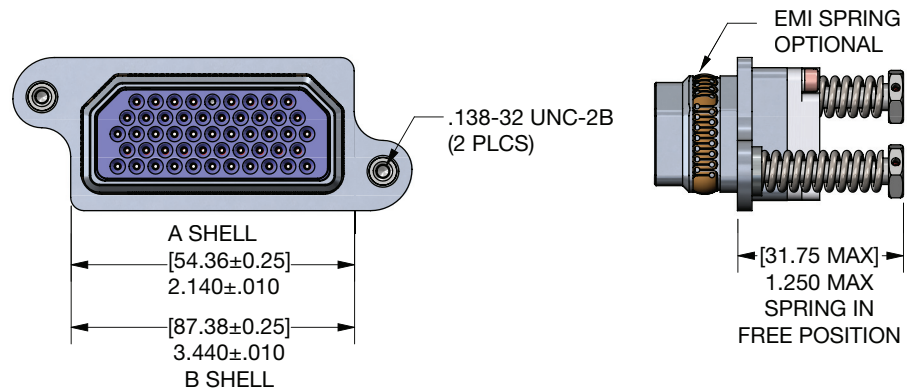

## TYPE K SOCKET MILITARY, PIN COMMERCIAL TYPE

M83733/4  
TYPE 'K' SOCKET  
MILITARY

TYPE 'K' PIN  
COMMERCIAL

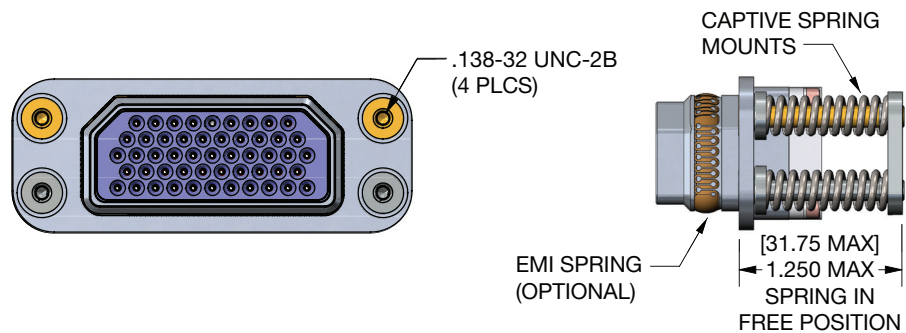

## TYPE M PIN

M83733/9  
TYPE 'M' PIN

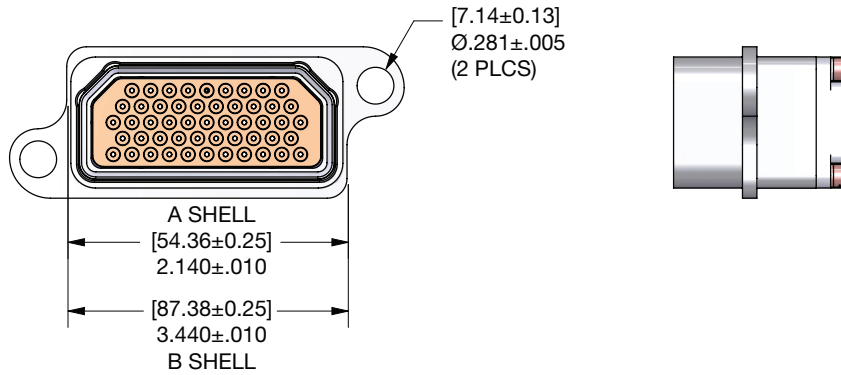

## TYPE X SOCKET

M83733/2  
TYPE 'X' SOCKET

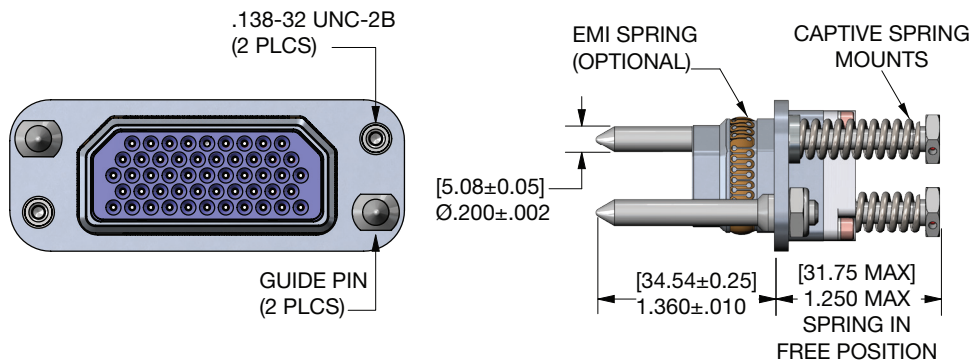

## TYPE X PIN

M83733/3  
TYPE 'X' PIN

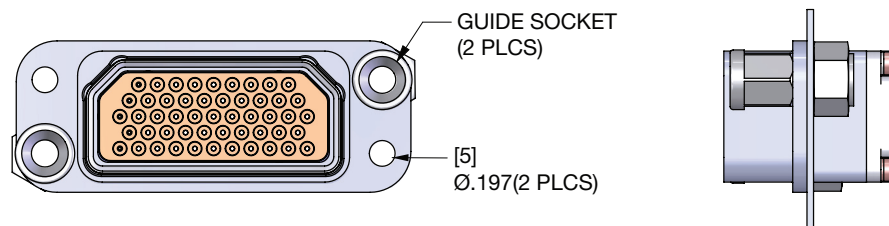

# Mounting Styles Y Socket & Pin, and Z Pin

R58

## TYPE Y SOCKET

M83733/7  
TYPE 'Y' SOCKET

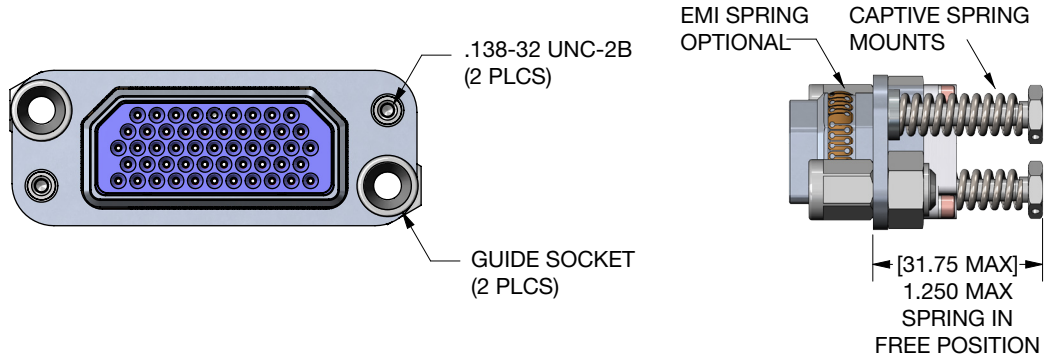

## TYPE Y PIN

M83733/8  
TYPE 'Y' PIN

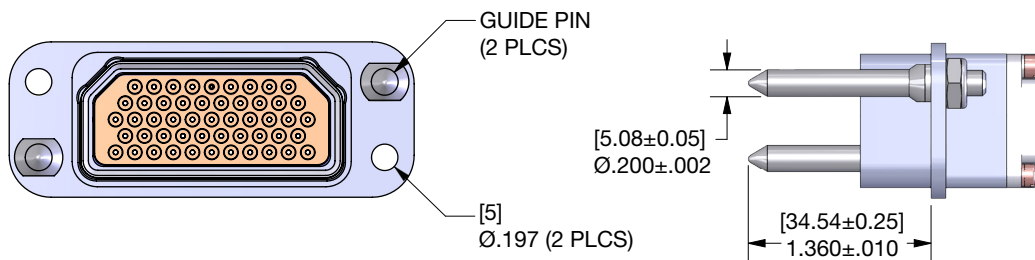

## TYPE Z PIN

M83733/11  
TYPE 'Z' PIN

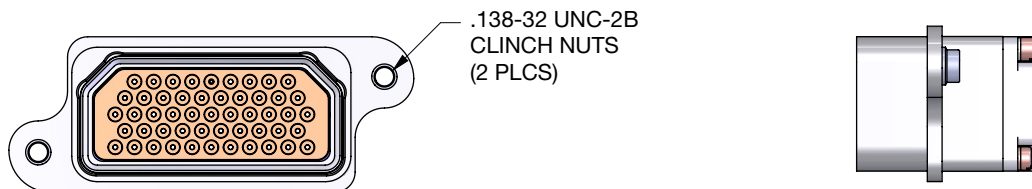

1. RoHS Compliance	2. Connector Series	3. Shell Size	4. Backshell	5. Backshell Style	6. Plating	7. Customer Number
<b>E</b>	<b>R58-</b>	<b>B</b>	<b>A</b>	<b>1</b>	<b>N-</b>	<b>XXX</b>

### 1. ROHS COMPLIANCE

<b>E</b>	RoHS Compliant (Omit for non-RoHS compliant)
----------	--

### 2. CONNECTOR SERIES

<b>R58-</b>	Rectangular
-------------	-------------

### 3. SHELL SIZE

<b>A</b>	Small Shell
<b>B</b>	Large Shell

### 4. BACKSHELL

<b>S</b>	Straight
<b>R</b>	Right Angle
<b>C</b>	Custom

### 5. BACKSHELL STYLE

<b>1</b>	Split, Saddle Clamp
<b>2</b>	Split, EMI
<b>3</b>	One Piece, Sealed, EMI
<b>4</b>	One Piece, Saddle Clamp

### 6. PLATING

<b>N-</b>	Electroless Nickel
<b>O-</b>	OD Chromate
<b>Z-</b>	Zinc Nickel
<b>C-</b>	Yellow CAD

### 7. CUSTOMER NUMBER

<b>XXX</b>	Customer Number
------------	-----------------

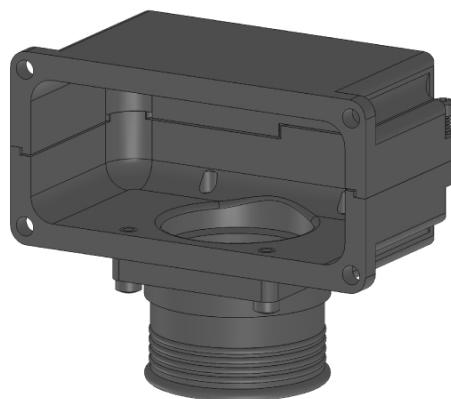
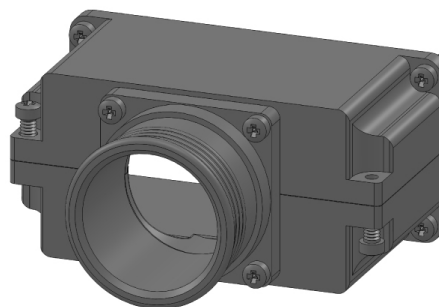

## FILTER CONNECTOR DESIGN

Filter connectors have been used for over thirty years to provide cost and space effective solutions to EMI problems in a wide range of military and commercial applications including avionics systems, satellites, missiles, communications, control systems and tempest equipment. A low pass filter connector incorporates capacitors and/or ferrite inductors into the connector body. The two capacitor types commonly used in filter connectors for military or avionics applications are planar arrays and tubular capacitors. Each of these capacitor types is an efficient filter at high frequencies (Up to 1GHz) and has been proven to be extremely reliable when suitably assembled into a connector. Both planar and tubular designs feature Amphenol's unique solder-less construction which reduces stress on the ceramic elements and results in superior physical and thermal shock capabilities.

## CAPACITOR TYPES

### PLANAR ARRAY DESIGN

Amphenol Canada's planar design consists of planar ceramic capacitor arrays with optional ferrites assembled concentrically over the contacts and into the connector shell. The planars are compressed between rubber gaskets and have contact springs in each position which form a stress isolated connection with the contact body. The planars are grounded to the shell via a ground spring.

### TUBULAR DESIGN

Amphenol Canada's tubular design consists of a ceramic tubular capacitor assembled onto a machined contact. The filter tube is connected to the contact with conductive rubber washers to provide a stress-isolated contact assembly. Grounding is achieved via a ground plate.

## WHY USE AN ACC FILTER CONNECTOR

ACC uses a stress-isolated planar array utilizing retention clips instead of solder to electrically connect the planar to the contacts. This provides a more robust and durable design with respect to the typical shock and vibration of aerospace applications. Stress-isolated planar arrays out performs discrete filters by blocking out the radiated EMI as well as filtering out conducted EMI. The ground plate of a tubular design or the internal ground electrodes of a planar design are connected to the shell with minimal aperture size and present an effective barrier to radiated EMI passing through the insert cavity.

- Fewer components = Cost Effective
- Space Saving on the PCB
- Increased Reliability (Solder-less Designs)
- For retrofit applications or late design-in
- Effective against radiated and conducted EMI

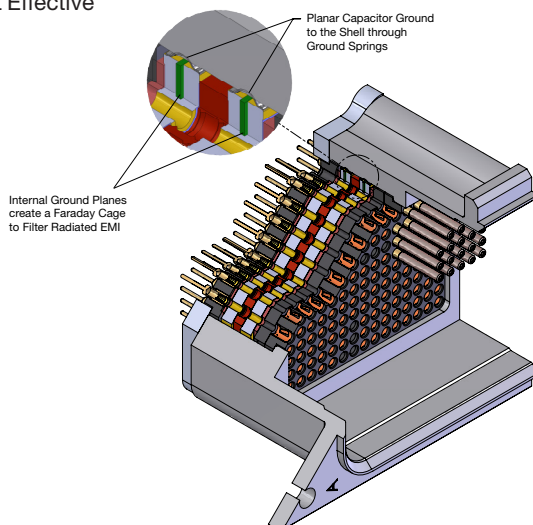

## WHAT DOES A FILTER CONNECTOR DO?

A filtered connector filters out noise and cleans a signal through a low pass filter. They allow low frequency signals to pass through, but filter out the higher frequency signals noise/EMI.

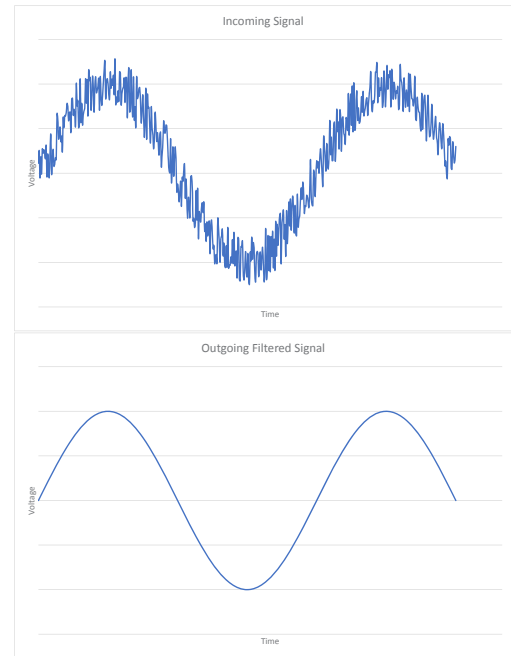

## ELECTROMAGNET INTERFERENCE (EMI) TYPES: CONDUCTED & RADIATED

Once in a system, EMI can distort signals and can interfere with system functionality. EMI can get into the system through conduction or radiation. Conducted EMI travels through the physically connected lines caused by other electronic devices in the system. Radiated EMI travels through air waves and can affect physically isolated lines.

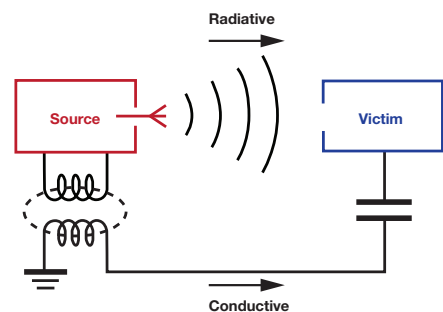



## FILTER CONNECTOR SELECTION

Selection of a particular filter circuit will depend on the required insertion loss characteristics and the system source and load impedances. By arranging the capacitor and ferrites in a variety of combinations a number of equivalent circuits may be attained. The ferrite elements always face the low impedance side of the filter. These filter types are available in a wide range of capacitance and voltage values and may be selected in virtually any combination within the connector insert. In addition to filter contacts, isolated contacts and ground contacts are available.

The following factors may affect the filter performance, and should be considered when selecting a filter connector and Amphenol Canada takes these into account when designing your filter solution.

## FILTER CONNECTOR PARAMETERS

Operating/working voltage is specified for the normal signal line voltage. Dielectric Withstanding Voltage (DWV) is specified for the transient voltage surges.

Operating currents cause magnetic saturation of inductive elements (ferrites). Therefore filters with ferrite inductors (Pi, CL, LC and T) will perform much like C filters as the ferrite approaches saturation. The saturation point can vary by ferrite characteristics and size but typically occurs above 0.1 A. The DC current rating through the contact is much higher and only depends on the contact size.

Capacitance and filters can operate between -55°C to +125°C; however, the performance can degrade with changes in the temperature. Capacitance and insertion loss performance are shown at 25°C. The typical high capacitance (>500pF) dielectric (X7R) has temperature coefficients of ±15% from -55°C to +125°C. The typical low capacitance (<500pF) dielectric (C0G) has a negligible temperature coefficients of ±0.3% from -55°C to +125°C.

Additional transient voltage suppression requirements such as lightning strikes may necessitate the addition of diodes or MOV's to the PCB or in the connector.

## CAPACITOR FILTER (C)

- 20 dB per Frequency Decade Typical Increase in Attenuation Slope
- Used mainly for High Frequency Noise
- With High Source and Load Impedance

## L FILTER (L-C)

- 20 dB per Frequency Decade Typical Increase in Attenuation Slope
- Used where Source and Load Impedance are Dissimilar
- Ferrite Side of Filter is Connected to Lower Impedance Side of Circuit
- Capacitor Side to Higher Impedance Side

## PI FILTER (C-L-C)

- 40 dB per Frequency Decade Typical Increase in Attenuation Slope
- Used where Applications Contain Relatively Higher Source and Load Impedance

## T FILTER (L-C-L)

- 20 dB per Frequency Decade Typical Increase in Attenuation Slope
- Used where Applications Contain Low Source and Load Impedance
- Switch-mode Power Supplies are Typical Applications

FILTER TYPES	FILTER CIRCUIT	BEST FILTERING APPLICATION
PI		Unknown or medium source and load Impedance
LC		Low impedance on mating side, high impedance on termination side
CL		High impedance on mating side, low impedance on termination side
C		High source and high load impedance
T		Low source and low load impedance

High source or load impedance >100ohms

Low source or load impedance >10ohms

# Filter Construction, Technical Details

R58

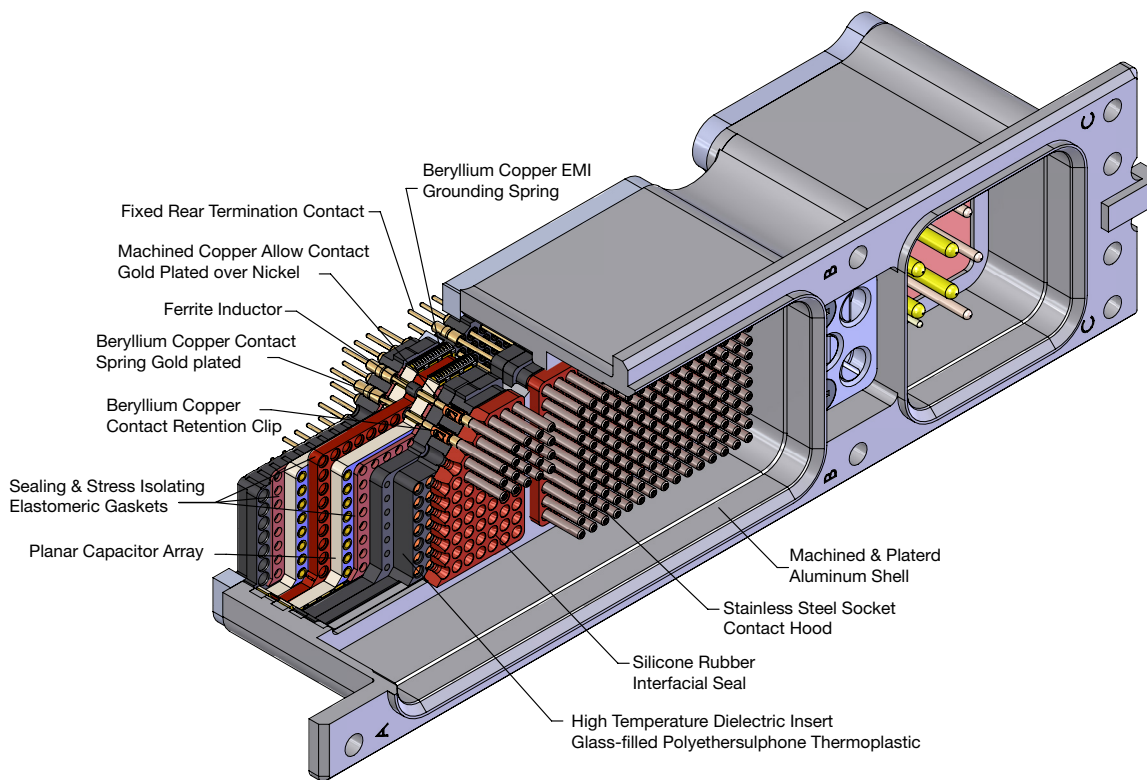

TYPE FILTER	PI				C, LC, CL, T						
	PA4	P02	P04	P08	CA2	C01	C02	C04	C22	C50	
Capacitance	400-800 pF	1.8-3.6 nF	4-8 nF	8-16 nF	200-400 pF	0.9-1.8 nF	1.8-3.6 nF	4-8 nF	22-40 nF	50-100 nF	
Insertion Loss (dB)	300 KHz	-	-	-	-	-	-	-	2	3	
	1 MHz	-	-	1	3	-	-	-	1	9	
	10 MHz	1	7	13	18	-	4	8	13	26	
	100 MHz	14	32	44	53	8	20	25	30	43	
	1 GHz	49	60	60	63	25	35	40	46	46	
Working voltage (VDC) (@ 25° & sea level)	200										
Dielectric Withstand voltage (VDC) (@ 25°C & 50 mA max charging current)	500										
Insulation Resistance (Gohms) (min) (@ 25°C & working voltage)	10										
Current Rating by Contact Size (continuous max, DC amperes)	#22 = 5 Amps #20 = 7.5 Amps #16 = 13 Amps #12 = 23 Amps										
Dissipation Factor @ 1kHz	3% Max										

Note: Other capacitance values, mixed capacitance arrangements, ground and isolated contacts are available. Consult the factory for your particular applications.

\*Acceptance testing performance to 1 GHz maximum

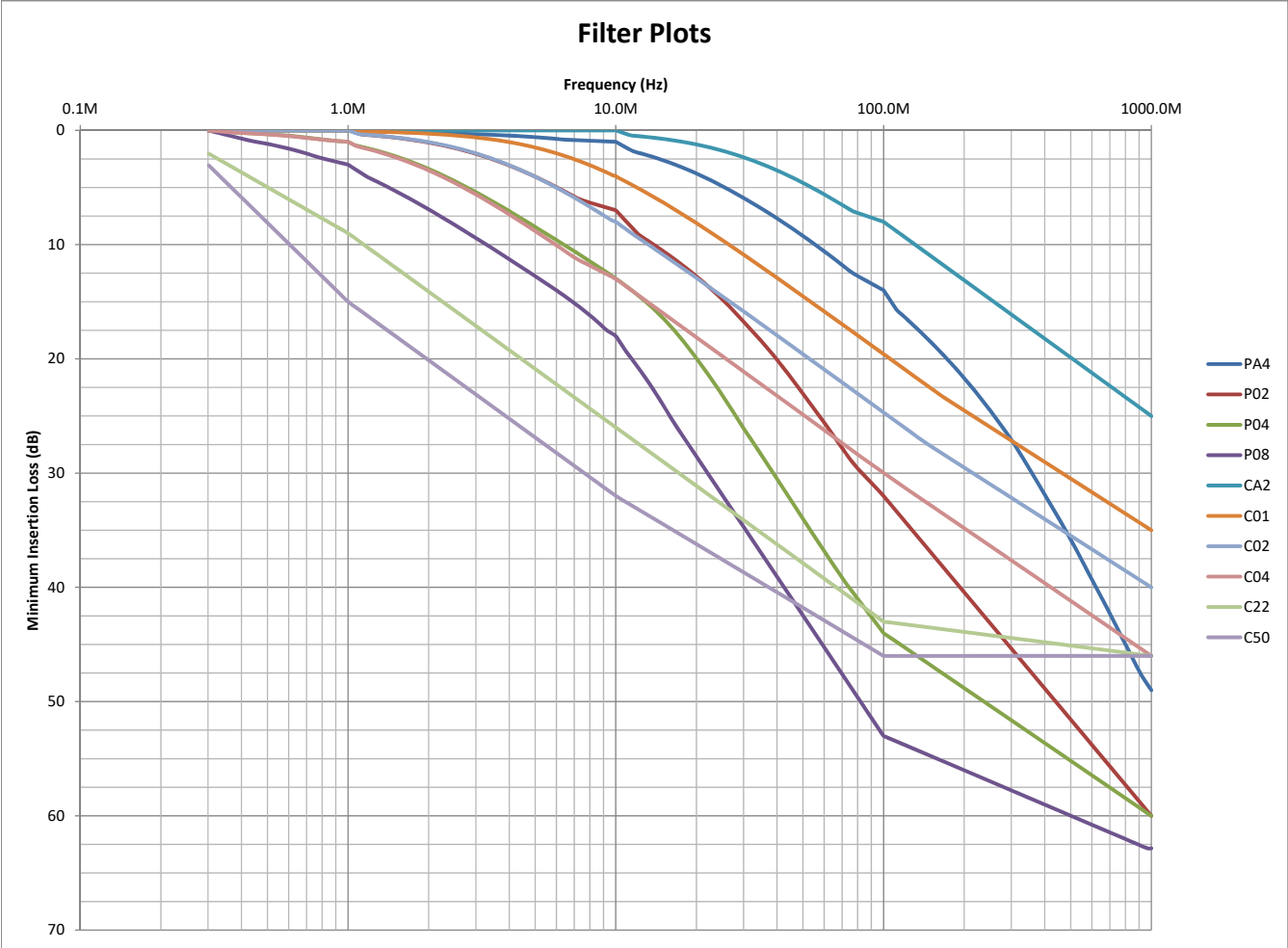

# How to Order Filter R58

R58

## PART NUMBER KEY

1. Filter	2. Shell Size	3. Insert Pattern	4. Contact Gender	5. Termination Style	6. Filter Style	7. Customer Number
485-	A	051	P	S	P08-	XXX

## STEPS

STEPS	PART #	DESCRIPTION
<b>1. FILTER</b>	<b>458-</b>	83733 Filter Connector
<b>2. SHELL SIZE</b>	<b>A</b>	A Size Shell
	<b>B</b>	B Size Shell
<b>3. INSERT PATTERN FOR SHELL SIZE A</b>	<b>018</b>	18x Size 12 Contacts
	<b>032</b>	32x Size 16 Contacts
	<b>36F4</b>	36x Size 20 Contacts, 4x Size 16 Fiber Contacts
	<b>051</b>	51x Size 20 Contacts
	<b>084</b>	86x Size 22 Contacts, 2x Coax Contacts
	<b>105F4</b>	101x Size 22 Contacts, 4x Size 16 Fiber Contacts
	<b>131</b>	131x Size 22D Contacts
<b>3. INSERT PATTERN FOR SHELL SIZE B</b>	<b>030</b>	30x Size 12 Contacts
	<b>048</b>	30x Size 16 Contacts, 18x Size 12 Contacts
	<b>59W7</b>	32x Size 16 Contacts, 7x Coax Contacts
	<b>064</b>	64x Size 16 Contacts
	<b>071</b>	56x Size 20 Contacts, 15x Size 12 Contacts
	<b>078</b>	38x Size 20 Contacts, 40x Size 16 Contacts
	<b>101</b>	101x Size 20 Contacts
	<b>161</b>	161x Size 22 Contacts
	<b>185</b>	185x Size 22D Contacts
<b>4. CONTACT GENDER</b>	<b>P</b>	Pin (Receptacle)
	<b>S</b>	Socket (Plug)
<b>5. TERMINATION STYLE</b>	<b>B</b>	PCB
	<b>S</b>	Solder Cups
	<b>T</b>	Crimp
<b>6. FILTER STYLE 'C' CIRCUIT</b>	<b>CA2-</b>	200-400 (pF)
	<b>C01-</b>	1800-3600 (pF)
	<b>C02-</b>	4000-8000 (pF)
	<b>C10-</b>	8000-16000 (pF)
<b>6. FILTER STYLE 'PI' CIRCUIT</b>	<b>PA4-</b>	400-800 (pF)
	<b>P02-</b>	1800-3600 (pF)
	<b>P04-</b>	4000-8000 (pF)
	<b>P08-</b>	8000-16000 (pF)
<b>7. CUSTOMER NUMBER</b>	<b>XXX</b>	

---

---

---

---

---

---

---

---

---

---

---

---

---

---

---

---

---

---

---

---

---

---

---

**R58**

---

---

---

---

---

---

---

---

---

---

---

---

---

---

---

---

---

---

---

---

---

---

---

---

---

---

# Amphenol



## Amphenol Canada

5950 14th Avenue  
Markham, ON  
Canada, L3S 3K5  
416-291-4401

## Amphenol Aerospace Operations

40-60 Delaware Avenue  
Sidney, NY 13838  
800-678-0141

## Amphenol Commercial Air Division

40-60 Delaware Avenue  
Sidney, NY 13838  
800-687-0141

## Amphenol Nexus Technologies

50 Sunnyside Avenue  
Stamford, CT 06902  
203-327-7300

## Amphenol PCD

72 Cherry Hill Drive  
Beverly, MA 01915  
978-624-3400

## Amphenol SV Microwave

2400 Centrepark West Drive  
West Palm Beach, FL  
561-840-1800

## Amphenol Times Microwave, Inc.

358 Hall Avenue  
Wallingford, CT 06492  
800-867-2629

## Amphenol Fiber Systems International

1300 Central Expressway North, Suite 100  
Allen, TX 75013  
214-547-2400

## Amphenol Borisch Technologies

4511 East Paris AVE  
Grand Rapids, MI 49512  
616-554-9820

## Amphenol Printed Circuits

91 Northeastern Boulevard  
Nashua, NH 03062  
603-324-4500

## Amphenol Invotec

Unit 1-3, Hedging Lane Industrial Estate  
Dosthill, Tamworth, B77 5HH United Kingdom  
+44 (0) 1827 263250

## Amphenol Ionix Systems

Prospect House, Taylor Business Park  
Risley, Warrington, WA3 6HP United Kingdom  
+44 (0) 1942 685200

## Amphenol Limited

Thanet Way  
Whitstable, Kent, CT5 3JF United Kingdom  
+44 (0) 1227 773200

## Amphenol Socapex

948 Promenade De L'Arve – BP 29  
74311 Theyz France  
+33 (0) 4 50 89 28 00

## Amphenol Air LB SAS

2 Rue Clément Ader, Zac de Wé  
08110 Carignan France  
+33 (0) 03 24 22 78 49

## Amphenol AirLB GmbH

Am Kleinbahnhof 4  
D-66740 Saarlouis Germany  
+49 (0) 68 31/98 10 0

## Amphenol SEFEE

Z.I. des Cazes – BP243  
12402 Saint-Affrique Cedex France  
+33 (0) 5 65 98 11 00

## Amphenol Interconnect India

105, Bhosari Industrial Area  
Pune – 411 026 India  
+91 20 27120363

## Amphenol Japan, Ltd.

471-1, Deba, Ritto-City  
Shiga, 520 3041 Japan  
+81 77 553 8501

## Amphenol Martec Limited

St. Augustines Business Park  
Swalecliffe, Whitstable, Kent  
CT5 2QJ United Kingdom  
+44 (0) 1227 793 733

## Amphenol Optimize

Carretera Internacional Km 6.5  
Col. Parque Industrial  
Nogales, Sonora, México. C.P. 84094  
+52 (631) 311-160

## Amphenol Ionix Systems OÜ

Pikk Street 59b  
Kuressaare 93815 Estonia  
+372 4521 780

## AMAO – European Sales Operations

Via Barbaiana 5  
20020 Lainate Milano, Italy  
+39 02 932 541

## Amphenol Bar-Tec Ltd.

3 Hagavish st  
POB 2479 Kfar-Saba 44641  
Israel  
+972-9-7644100

# Amphenol CANADA

MILITARY & AEROSPACE

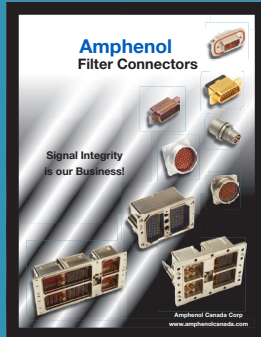

Filter Connectors Catalog



Rectangular Catalog



Microminiature Catalog

Visit <http://www.amphenolcanada.com/media> for literature, product data sheets, videos and Patents



R27 Catalog



ARINC 600 Catalog



ARINC 404 Catalog

## AMPHENOL CORPORATION

5950 14th Avenue, Markham, ON L3S 4M4 • 416-291-4401

[www.amphenolcanada.com](http://www.amphenolcanada.com)